

ROKSAN



ROKSAN AUDIO LIMITED
6 NORTHFIELD INDUSTRIAL ESTATE
BERESFORD AVENUE ALPERTON
MIDDLESEX HA0 1NW ENGLAND
TEL. +44 (0)20 8900 6801 / 6802
FAX. +44 (0)20 89000734
www.roksan.co.uk
Email info@roksan.co.uk

PRINTED IN ENGLAND

Congratulations on your purchase of the ROKSAN Kandy **K2** Integrated Amplifier. This Integrated Amplifier is designed and manufactured to the highest specification and rigorously tested to reward you with many years of listening pleasure.

Your Kandy **K2** Integrated Amplifier is at the heart of your hi-fi system. Its correct installation, set-up and operation will have a profound influence on the sonic performance of the entire hi-fi installation.

Please read the contents of this manual thoroughly. It will help you to understand your hi-fi equipment better and enhance your listening pleasure.

This manual is divided into the following sections:

- Safety Instructions (*Accompanying card*)
- Introduction
- Cautions
- Installation
- Setup
- Operation
- Troubleshooting
- Guarantee
- Specifications
- Notes

UNPACKING

Included in the packing of your Kandy **K2** Integrated Amplifier you will find:

- One mains lead fitted with the correct mains power plug for your country
- One Roksan Programmable Learning Remote Handset **RMX-108** and AAA batteries (x4)
- One information pack and warranty card

After removing these items please retain **all** packing materials. Correct packing is necessary for future transportation of your Kandy **K2** Integrated Amplifier.

MAINTENANCE

After disconnecting the Kandy **K2** Integrated Amplifier from the mains supply, the cabinet and front panel may be cleaned with a lightly dampened soft cloth or chamois leather. **Avoid using abrasives or solvents.**

EU DIRECTIVES

This product is designed to comply with the legal provisions of EU Directives 89/3336/EC and 72/23/EC. The standards which have been applied are those which were in force at the time of the introduction of this product.

This product bears the CE mark.



This product is compliant to EN 60065.

This product must be earthed. Please ensure that other equipment connected to it is earthed according to the manufacturer's instructions.

AC MAINS SUPPLY

Your Kandy **K2** Integrated Amplifier is set to operate from a fixed supply voltage which is marked on a label next to the mains input plug. Before connecting the mains lead please check that your mains supply corresponds to this label as below:

230V Products	Voltage Range: 220V – 240V
115V Products	Voltage Range: 110V – 120V
100V Products	Voltage Range: 90V – 110V

The mains lead supplied with this product has an IEC mains socket which plugs into the IEC connector on the unit's rear panel. The other end is normally attached to the appropriate mains plug for your country. In the UK this is the standard UK13A plug.

This plug should ordinarily not be removed from the lead. If you *do* remove it, please dispose of it safely so that it cannot be plugged into a mains socket whilst in a potentially dangerous condition. We suggest that you obtain from your dealer a complete replacement lead.

Should you move to another area where either the mains voltage or the mains plugs are different from those as supplied with your Integrated Amplifier, please contact the appointed ROKSAN distributor for assistance.

Please observe correct mains polarity at all times.

The Integrated Amplifier mains fuse is located on the rear panel next to the IEC mains connector. This must only be replaced by the fuse of the type and rating as described on the fuse rating label on the rear panel of the unit.

This product requires connection to earth (ground). The earth wire (in the UK this is colour coded green/yellow) of the mains cable supplied with your Integrated Amplifier must be connected to a suitable earthing point established for this purpose by your electricity supply company. If you are in any doubt, consult a qualified electrician.

If the equipment is likely to be unattended for some time, unplug it from the mains supply.

GENERAL CAUTIONS**FCC WARNING**

This equipment may generate or use Radio Frequency energy. The user may lose the right to operate this equipment if unauthorised modifications are made.

INTERFERENCE

Properly installed, this unit should not cause harmful interference to radio communications, There is, however, no guarantee that such interference will not occur in a specific installation. If interference arises (which you can determine by switching the unit off and on) you could try to remedy matters by the following:

- Re-orient or re-locate the receiving antenna
- Increase the distance between the Kandy Integrated Amplifier and receiver
- Connect the unit to a different mains circuit from that of the receiver
- Consult your ROKSAN appointed dealer or an experienced Radio/TV technician for help and advice

LOCATION

Your Kandy **K2** Integrated Amplifier should be located in a well ventilated area and kept away from sources of heat, dust and humidity and from direct sunlight.

The Integrated Amplifier may be positioned either as a free standing unit or alongside another audio/video product.

Never place the Integrated Amplifier on carpet or any surface likely to hinder normal ventilation.

Never allow liquids or other objects to fall into the unit.

This unit contains no user serviceable parts. **Do Not remove any panels or attempt to service it yourself.**

Unauthorised servicing will void the warranty.

ROKSAN Kandy K2 Integrated Amplifier- Front Panel View

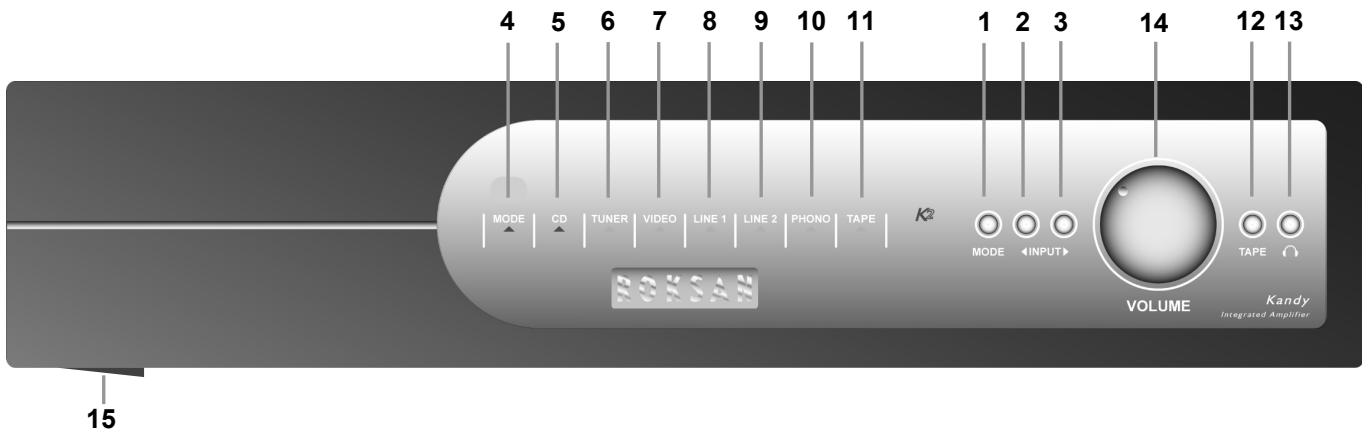

- | | |
|--|--|
| <ul style="list-style-type: none"> 1 Mode Button 2 Input Button (Back) 3 Input Button (Forward) 4 Mode Indicator 5 CD Input Indicator 6 Tuner Input Indicator 7 Video Input Indicator 8 Line 1 Input Indicator | <ul style="list-style-type: none"> 9 Line 2 Input Indicator 10 Phono Input Indicator 11 Tape Monitor Indicator 12 Tape Monitor Button 13 Headphone Socket (3.5mm Jack) 14 Volume Control 15 AC Mains Power Switch |
|--|--|

NOTE: There is a peel off protective film on the 'mirror' display.

ROKSAN Kandy K2 Integrated Amplifier - Rear Panel View

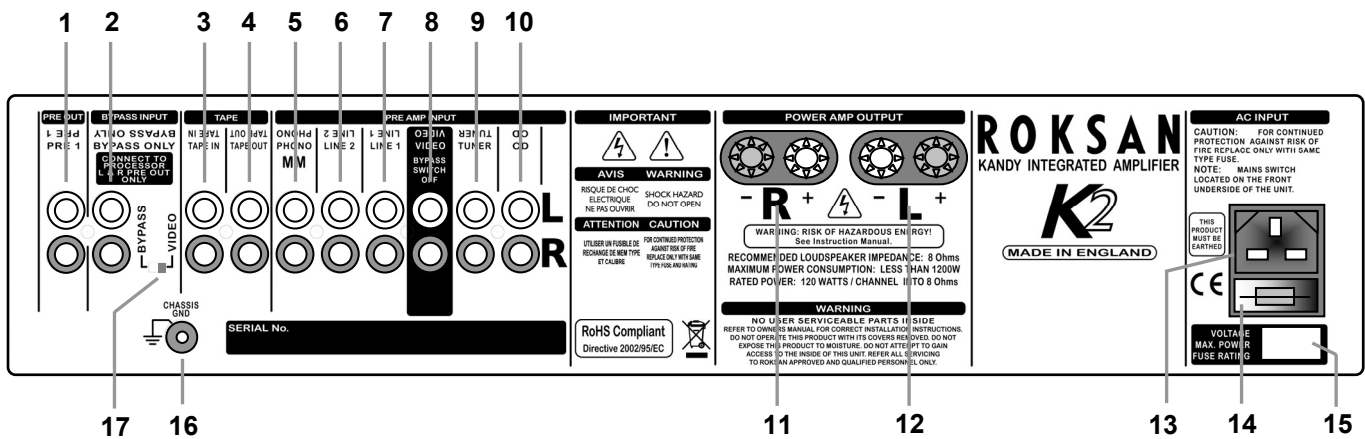

- | | |
|---|---|
| <ul style="list-style-type: none"> 1 Pre amp Output 1 (Multi-Amping or Subwoofer) 2 Bypass Input (When Bypass switch is set to ON) 3 Tape Input (Playback) 4 Tape Output (Record) 5 Phono Input (Moving Magnet) 6 Line 2 Input 7 Line 1 Input 8 Video Input (When Bypass switch is set to OFF) 9 Tuner Input | <ul style="list-style-type: none"> 10 CD Input 11 Right Speaker Output 12 Left Speaker Output 13 AC Mains Input 14 AC Mains Fuseholder 15 Voltage & Fuse Label 16 Phono Input/Chassis Grounding Terminal 17 Bypass Switch (Selects between Video & Bypass Inputs) |
|---|---|

CONNECTING MAINS POWER

Please refer to the front & rear panel view on Page 4. The moulded IEC connector of the supplied mains lead should be plugged into the socket (13) on the rear of the unit first and then plugged into the mains supply. The Mains power switch (15) is on the front underside of the Integrated Amplifier. This switch can be left on; if however the amplifier is likely to be unattended for a long period, switch it off and unplug the mains lead from the wall.

SIGNAL CONNECTIONS

Signal Input connections:

There are 6 Inputs (5 – 10) on your Kandy Integrated Amplifier in addition to the Tape Input (3). Except for the PHONO input (5), all other inputs are line level and will accept virtually all currently available source components. The PHONO input is factory set for Moving Magnet Cartridges to accommodate record players fitted with MM phono cartridges. The VIDEO input (8) is linked to the BYPASS input (2) and Switch (17). When the Bypass Switch is set to VIDEO, then the VIDEO input will function as a line level input. When the switch is set to BYPASS, then the VIDEO input will be deactivated and the BYPASS input will become activated. In this mode, the BYPASS input can be used for connection to a surround sound processor's front L&R pre output for home theatre use. The BYPASS input is directly connected to the power amp section and bypasses the preamp. The volume is then controlled via the surround sound processor and not the Kandy integrated. *You could also use the integrated as a power amp in this mode.*

All the inputs use Gold plated RCA Phono Connectors and should be connected according to the standard convention – **Right Channel – Red; Left Channel – Black or White.**

Also in accordance with standard practice, the Upper row of Phono Sockets carries the Left Channel and the Lower row carries the Right Channel.

The Input Sockets are labeled with their legends upside down as well as the normal way up to assist you should you be connecting an input from a position in front of and above the amplifier.

MC Input Connections:

If you wish to use a Moving Coil cartridge, an in-line MC step-up transformer should be connected to the Phono Input. Alternatively a dedicated Phono Stage can be connected to a Line level Input (**NOTE:** If you wish to connect to the Phono Input, it must be set for Line level signal. See above). *For advice and demonstration of ROKSAN state of the art turntable reproduction systems contact your authorised retailer.*

IMPORTANT NOTE: For optimum performance it is recommended to use high quality inter-connect cables such as ROKSAN **HDC-02A** High Definition Analogue Cable.

LOUDSPEAKER CONNECTIONS

The right and left loudspeakers are connected to the amplifier via the rear panel binding posts (11) and (12) respectively. There are two basic types of cable –

- **Figure 8 cable** has two insulated conductors which lie parallel, either side by side, or spaced by insulation.
- **Overall sheathed cable** has both conductors insulated and enclosed in an overall plastic sheath.

Carefully remove any overall sheath or split the figure 8 cable to a depth of about 75mm (3"). Carefully strip the insulation on each wire to a depth of about 12mm (1/2") exposing the bare core. If the conductor is stranded, twist the strands together on each conductor.

Unscrew the binding post. There is a cross-hole about 5mm from the panel end of the binding post. Insert the bared conductor through the hole and tighten the binding post securely making sure that there are no loose strands or bare ends protruding through the post.

Carefully observe polarity ensuring that the RED (+) speaker terminal is connected to the RED (+) amplifier terminal and the BLACK (-) speaker terminal to the BLACK (-) amplifier terminal. When both left and right channels are connected to their respective speakers the amplifier is ready for use.

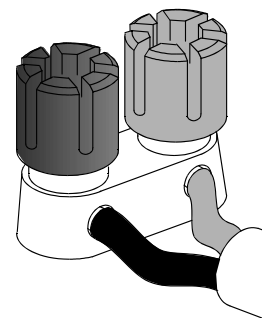

IMPORTANT NOTE: For optimum performance it is recommended to use high quality cables such as ROKSAN **HDC-02S** High Definition Loudspeaker Cable. Many speaker cables such as the ROKSAN **HDC-02S** are directional. Please observe this characteristic. **DO NOT** use a speaker cable with conductor size less than 16 AWG (1.6mm Diameter). The Binding posts accept conductor sizes up to 12 AWG.

If the Loudspeakers utilise more than one drive unit with individual input terminals, for example a Tweeter and a Woofer, then the loudspeaker performance should benefit from Bi-Amping. Dedicating one amplifier to the Tweeter and another to the Woofer isolates them from each other hence reducing distortion and increasing reserved power. Speakers work far better with most amplifiers when Multi-Amped than using one yet more powerful amplifier.

For setup and connection details on Multi-Amping refer to the Kandy Power Amplifier Manual.

Note: Multi-Wiring connects the Woofer and the Tweeter terminals directly to the output terminals of the amplifier and is the first step towards Multi-Amping.

MULTI-WIRING THE LOUDSPEAKERS

Tri-wired Speaker

Bi-wired Speaker

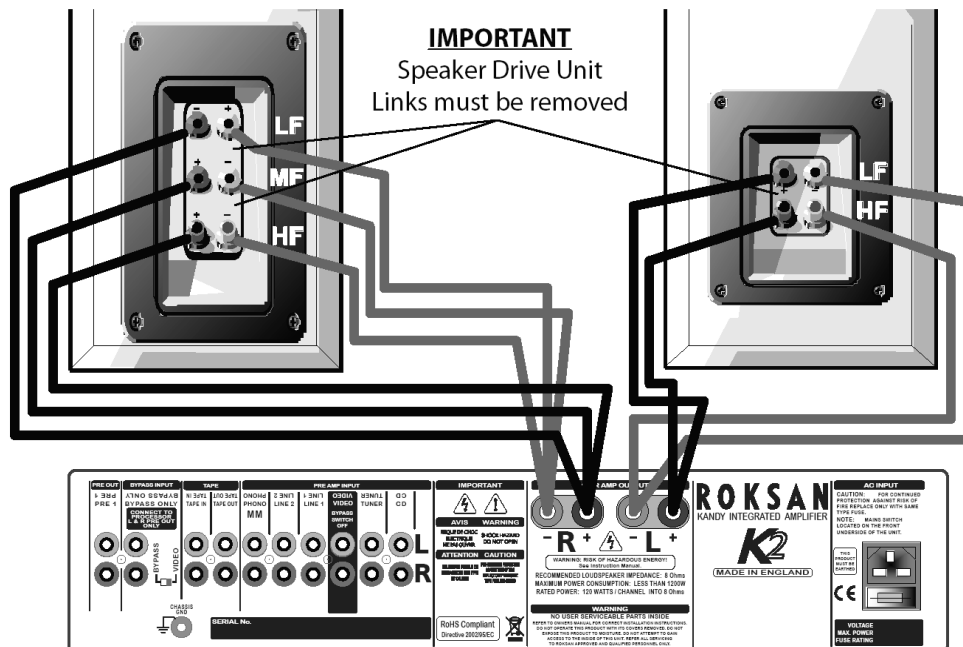

OPERATION *K a n d y K2 Integrated Amplifier*

Please refer to the front and front & rear panel views on page 4 and the Remote Handset View on page 8.

SWITCHING ON

The Mains power switch (15) is located on the front underside of the amplifier. This switch can be left ON for normal operation. If unattended for a long period (*Going on a short break, holidays etc.*) the Mains power should be switched OFF and the power cord disconnected from the mains power input.

When switched ON, the **K2** logo in the 'mirror' display will glow red and your Kandy Integrated Amplifier will be in STANDBY with the MODE indicator (4) illuminated in GREEN. *The amplifier is now ready for use.*

You can activate your Kandy Integrated Amplifier in two ways:

- 1 Press the MODE button **(1)** on the front panel once.
- 2 Press the POWER button **(2)** on the remote handset once.

The Kandy Integrated will 'wake up', the MODE indicator illumination will change to RED, the CD input will be selected and the CD input indicator **(5)** will illuminate RED. The amplifier will then automatically check its input/output status and after a brief moment when no problems are detected, the speaker output relays will click on and the amplifier starts in normal operation mode responding to all front panel buttons and the remote.

USING THE CONTROLS

MODE CONTROL

The MODE button on the Front Panel **(1)** has the following functions:

- It activates the amplifier from Standby. **NOTE: From the Remote Handset, only the POWER Button (2) can put the amplifier in and out of standby.**
- Pressing the MODE button once with the amplifier activated will mute/lower the volume level by 20dB. The MODE indicator light will change to AMBER. The amplifier remains fully functional in this mode. Another single press, un-mutes the amplifier and the MODE indicator light will revert to RED.
- When the amplifier is activated, a sustained press on the MODE button will put the amplifier into Standby. All the input indicator lights will be extinguished and the MODE indicator light will change to GREEN.

NOTE: First time when you bring the Kandy out of STANDBY after switching it ON at the Mains, the input selector will default to CD (*as described previously*).

Subsequently however, bringing the Kandy out of Standby from Standby using the MODE or the POWER (*Remote handset*) buttons, will restore the selected input and tape values before it was put into Standby.

INPUT SELECTOR BUTTONS

The INPUT Selector Buttons **(2, Back)** and **(3, Forward)** march through the inputs one click at a time. They connect each signal source to the amplifier by marching through the Inputs with the exception of TAPE. Pressing the Forward Button **(3)** repeatedly will select inputs in this sequence:

CD - TUNER - VIDEO - LINE1 - LINE2 - PHONO - CD - ...

Pressing the Backward Button **(2)** repeatedly reverses the sequence.
Whenever an input is selected the appropriate indicator light will illuminate.

VOLUME CONTROL

The VOLUME Control is a precision device. It follows a logarithmic law so that its response approximates that of the human ear. There is an indicator on the volume control to show the appropriate volume setting.

TAPE MONITOR

When you select an INPUT, the selected source is connected to the amplifier and to the Tape Output Sockets **(4)** of the Kandy thus enabling you to record from the selected INPUT.

The Tape Monitor is an override. Pressing the TAPE button **(12)** connects the output of your tape deck to the Kandy, overriding the selected input. However, the selected input is left connected to the recording input of your tape deck. If you have a suitable tape deck, this facility enables you to record a programme whilst monitoring its playback.

When the TAPE button is depressed, the TAPE Indicator light **(11)** glows and the selected source Indicator remains illuminated.

The input selector remains functional when the Tape Monitor is ON thus allowing a range of sources to be recorded.

Pressing the TAPE button toggles between Tape Monitor ON and OFF.

REMOTE HANDSET

The Kandy **K2** Integrated Amplifier is supplied with Roksan's programmable, learning remote handset (**RMX-108**) and four AAA size 1.5V batteries.

Carefully remove the battery compartment cover and insert the supplied batteries in place observing **polarity**. Replace the cover. The handset is now ready for use.

The front panel controls of the Kandy Integrated Amplifier are replicated on the remote handset.

- 1 KANDY AMP/CD
- 2 POWER
- 3 TAPE
- 4 MODE
- 5 VOLUME (+)
- 6 VOLUME (-)
- 7 INPUT(FORWARD)
- 8 INPUT (BACK)
- 9 BACK LIGHT

NOTE:

The LCD display & the hand set will turn on as soon as the batteries are inserted. If the handset is left untouched for 90 seconds, it will automatically turn off the LCD to save battery life.

The handset is equipped with a motion sensor and thus will 'wake up' as soon as it is picked up.

The Back Light will only come on when the back light button is pressed and will stay on during operation. Back light will turn off automatically after 10 seconds if none of the buttons are pressed.

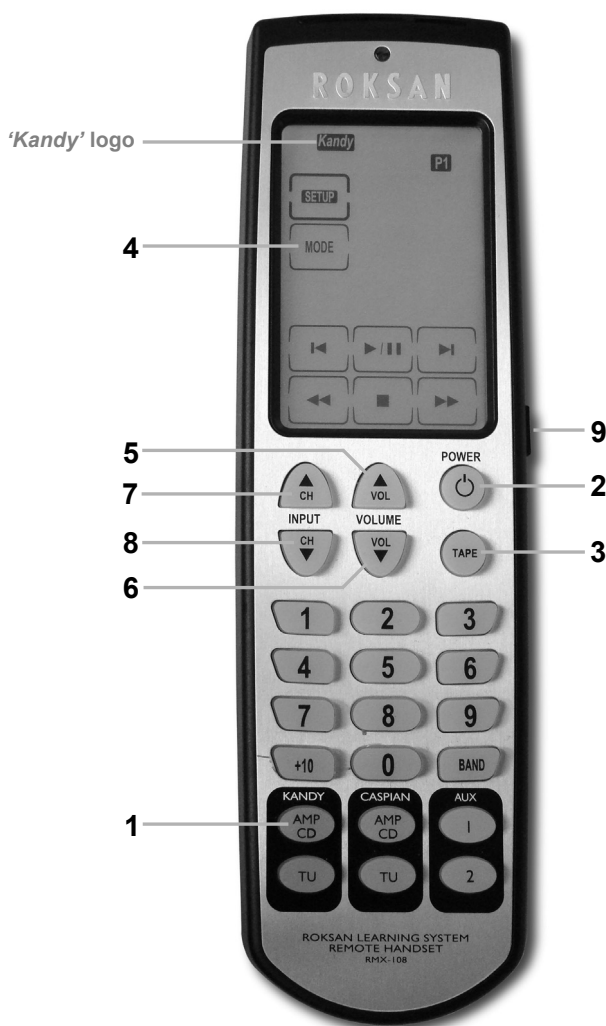

- 1 The KANDY 'AMP/CD' Button (1) selects Kandy Integrated and CD devices (**'Kandy' logo on LCD**).
- 2 The POWER Button (2) puts the amplifier in and out of Standby (**MODE light GREEN and RED**).
- 3 The TAPE Button (3) connects the Tape Deck In and Out.
- 4 The MODE Button (4) mutes and un-mutes the output level by 20dB. (**MODE light AMBER and RED**).
- 5, 6 The VOLUME Buttons (5 & 6) adjust the output volume level (**Increase & Decrease**).
- 7, 8 The INPUT Buttons (7 & 8) march through the input sources (**Forward & Back**).
- 9 The BACK LIGHT Button (9) turns on the handset buttons and the LCD display illumination.

KNOW YOUR KANDY

- When you first power up from the Mains Switch from the front underside of the amplifier, the amplifier goes into Standby and the MODE Indicator glows GREEN.
- In order to reduce power consumption and heat, the power stage of the amplifier is shut down when in Standby mode.
- In normal operation when an external fault such as a short circuit on the loudspeaker leads is detected, the amplifier will go into standby and the speaker output and AC power relays will disconnect and the MODE indicator light will glow GREEN. Unless the fault is rectified the amplifier can not be brought out of standby.
- If the amplifier output Current exceeds its safe operating range (very low loudspeaker impedance and/or very high volume level) the protective circuitry of the Kandy will take the amp into Standby mode. If subsequently the volume is lowered or the loudspeakers changed, the amplifier can be brought out of Standby to resume normal operation.

TROUBLESHOOTING

K a n d y **K2** *Integrated Amplifier*

If you suspect that your ROKSAN Kandy Integrated Amplifier is not operating properly, you should check all the connections carefully. Pay particular attention to speaker phasing and channel connections. Phono plugs should be fully inserted- a frequent cause of problems is that Phono plug surrounds do not make proper contact. Below are some commonly encountered problems with suggestions for possible cure. The list is not exhaustive: If you have any unresolved problems, please consult ROKSAN or your appointed ROKSAN dealer or distributor.

SYMPTOM	LIKELY CAUSE	SUGGESTED REMEDY
No power	AC Mains lead not inserted properly Unit not switched on	Ensure AC Mains lead is fully inserted Switch unit on (<i>on the front underside</i>)
No output on one or both channels	Amplifier in stand-by mode (MODE light GREEN) Missing or bad input signal connection Incorrect speaker connection Wrong input selected Tape Monitor selected	Press MODE button to set amplifier in operational mode (MODE light RED) Check all input connections Check speaker output connections on rear panel Select correct input, ascertain source is working Deselect Tape Monitor
Very low sound output	Amplifier set in 20dB MUTE position (MODE light AMBER)	Press MODE button to set amplifier in operational mode (MODE light RED) (Check volume setting first)
Poor speaker imaging, lack of Bass output	Loudspeakers connected out of phase	Check polarity of speaker connections (especially important if Multi-wiring, Multi-Amping)
Hum from speakers	Incorrect grounding	Check Mains polarity and grounding on all connected equipment

There are no user-serviceable parts inside your Kandy Integrated Amplifier. If a fault should develop; refer all servicing to your appointed ROKSAN retailer, distributor or ROKSAN approved service agent.

Your ROKSAN Kandy Integrated Amplifier is guaranteed against any defect in materials and workmanship for a period of **two years** from the date of purchase.

This guarantee only becomes effective if the warranty card is validated by the ROKSAN retailer from whom the equipment was purchased and returned to ROKSAN within **28 days** of purchase.

This guarantee excludes:

1. Damage caused due to accident, misuse, neglect and incorrect installation, adjustment or repair.
2. Liability for damage or loss during transit from the retailer or purchaser to ROKSAN or its authorised distributor for the purposes of repair or inspection.

Carriage costs to ROKSAN shall be borne by the consignor.

All claims under this guarantee must be made through an authorised ROKSAN retailer.

If equipment returned for repair to ROKSAN is found on inspection to comply with the product specification ROKSAN reserves the right to make a charge for examination and return carriage.

Unauthorised servicing will void this guarantee.

SPECIFICATIONS

K a n d y **K2** *Integrated Amplifier*

Inputs	Line Level (x5), Moving Magnet (x1), Tape (x1), Bypass (x1)
Input Impedance	47 kΩ
Input Sensitivity (120W)	Line 470mV
Outputs	Speaker L & R (x1), Preamplifier (x1), Tape (x1), Headphone (x1)
Output Power	>125 Watts, into 8Ω both channels driven >190 Watts, into 4Ω both channels driven
Power Supply	500VA Ultra Low Noise Toroidal Transformer 4 Regulated Supply Rails
Damping Factor	>110 (8Ω)
Frequency response	(-3dB), <3Hz – >100kHz
Gain	37.3dB Overall (Pre & Power) 5.7dB Preamplifier 31.6dB Power Amplifier
Harmonic Distortion	<0.005% 1kHz - 8Ω
Signal to Noise Ratio	Line 100dBa (ref 470mV)
Power Source	100V – 120V 50Hz / 60Hz 220V – 240V 50Hz / 60Hz
Power Consumption	Standby <25W, Full Power 2-CH 8Ω < 330 W, 4Ω <550W
Dimension	432 x 380 x 90 (W x D x H) mm 432 x 380 x 102 (including feet)
Weigth	14 Kg

NOTES

Kandy K2 Integrated Amplifier

Kandy Integrated Amplifier K2

Purchase Date

ROKSAN Retailer

Serial Number:

Year

Month

Day

Name:

Location:

Please keep a record for future reference



K2

w w w . r o k s a n . c o . u k